



# MoistTech Corp.™

*Moisture Measurement & Control From Lab To Line*

## 3000-IP67

IP67 Rated Enclosure for  
Online Measurement  
Near Infrared Measurement

ALCOHOL Moisture  
Engineered Wood  
Polymers  
BRICK  
CONTROL  
Adhesives  
OILS  
Plastics  
FATS  
PROTEINS  
Food  
Wood  
Tobacco  
BIOFUELS  
Improve  
Productivity  
CONVERTING  
Optimize Drying  
COATWEIGHT  
Thickness  
Paper  
Bulk Conveying  
POWDER  
Sinter  
Pellets  
GRAINS  
Fibers



# MoistTech's Online NIR Moisture Sensor

## 3000-IP67 WIDE ARRANGE OF APPLICATIONS INCLUDE:

- ✓ Adhesive
- ✓ Chemicals
- ✓ Coating
- ✓ Converting
- ✓ Food
- ✓ Forest Products
- ✓ Minerals
- ✓ Paper
- ✓ Pharmaceuticals
- ✓ Plastic
- ✓ Renewable Energy
- ✓ Snack Food
- ✓ Textiles
- ✓ Thickness
- ✓ Tobacco
- ✓ Web
- ✓ And More

In addition to measuring moisture the 3000-IP67 may be used to measure, display and control coating weight, sheet and film thickness, oil, protein and other elements that absorb NIR.

### PRODUCT INFORMATION

MoistTech developed the 3000-IP67 online NIR sensor to withstand wash-downs, dusty / dirty environments, and to protect it against the effects of immersion. Its rugged stainless steel enclosure makes it ideal for the harshest environments, aggressive process applications and the industry's extreme temperatures. IP67 include an integrated air vortex or liquid cooling system that is rated from 0°C to 93°C (200°F); additionally, insulation wraps are available.

Insensitive to material variations such as particle size, material height and color, the IR-3000 provides continuous, reliable readings. It's one-time calibration, maintenance free, drift free optical design allows operating personnel to confidently make immediate process adjustments based on real-time measurements.

Production efficiency improvements due to accurate real-time measurements provide both energy savings and potential increased productivity with lower material losses.

The IR-3000 uses state-of-the-art components allowing installation in the most extreme locations. As result of MoistTech's advanced digital processing, only the IR-3000 provides true data regardless of gaps and interruptions of product flow on the belt or screw conveyors.

### NEAR INFRARED (NIR) TECHNOLOGY

All molecular bonds absorb specific wavelengths of light. Hydrogen bonds including O-H (water); C-H (hydrocarbon) and N-H (ammonia) all absorb strongly in the NIR spectral region. The amount of NIR energy reflected at a given wavelength is inversely proportional to the quantity of absorbing molecules in a product.

The NIR technique is a non-destructive, non-contacting measurement. MoistTech's sensor utilizes multiple wavelengths of NIR light, projected onto the product at a very high repetition rate. The reflected light is then measured using a digitally enhanced detection system and thousands of data points are sampled every second.

### INSTALLATION LOCATIONS

The sensors can be installed using the bracket on the back of the sensor 4" – 16" (inches) from the product. The MoistTech sensor has many options for installation including:

- Belt, Screw, Drag & Enclosed Conveyors
- Chutes, Cyclones & Bins
- Dryer In/Out
- Webs
- Pipeline or Pneumatic Conveying using our Flange window or Sampler options.

### KEY BENEFITS FOR USERS:

#### Product Quality Monitoring

Allows immediate production line adjustments to improve product quality and consistency

#### Process Optimization

Allows 100% monitoring of your production process to reduce product that is "out of specification"

#### Fuel Consumption Savings

Reduce your energy usage as the drying/cooking process can be controlled resulting in a reduction in energy consumption

#### Water Savings

Reduce your water usage by continuously monitoring moisture content

#### Dust Prevention

Help reduce the risk of explosions due to dust

### DISPLAY OPTIONS

In addition to the MoistTech management software, MoistTech offers several read-out options to display and/or adjust the measurement outputs.

- Digital Panel Meter (DPM) connected by 4-20mA output
- Full Color Touch Operator Panel (OP-14) PLC based connected by RS-232C serial. (provides trending graph)
- Color Touch Operator Interface (OI) connected by Ethernet.

(OP-14 & OI provide operators & engineers the unlimited ability to make changes to gauge parameters, monitor diagnostics and program calibrations all at-line)

### MANAGEMENT SOFTWARE

MoistTech has designed a suite of high-tech Windows™ programs to provide user-friendly interfaces for configuration, data logging, and monitoring of diagnostics. With this you can perform calibrations, define gauge and measurement parameters, and set-up and configure up to 50 different product codes. The MoistTech Software package is easy to use and compatible with any PC platform.

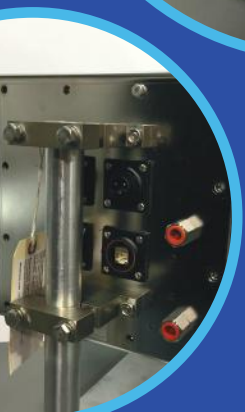
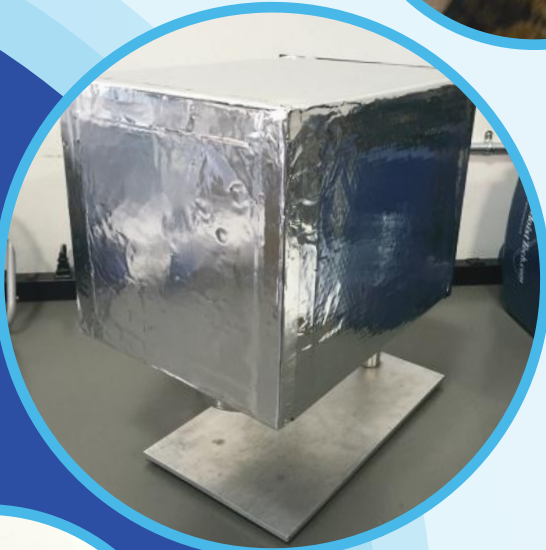
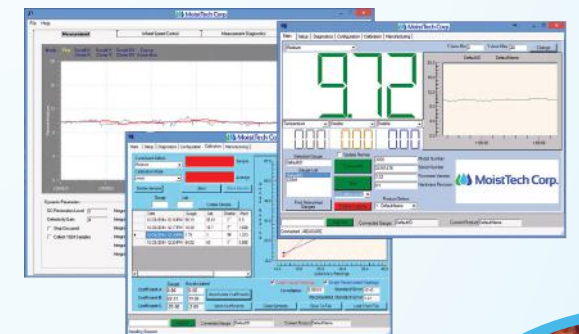

## STANDARD FEATURES INCLUDE

The enclosure for the standard IP67 sensor is a stainless steel welded sheet metal housing. It consists of a two-piece design wherein the optical bench is mounted in the internal chassis. A gasket is affixed to the air purge light tube and the outer housing. All the connectors are sealed to the outer housing as are the air cooling fittings. There is a built-in fan used with the vortex air cooling that the unit is normally fitted with.

The enclosure is rugged for hostile environments and complies with the IP-67 standards for water immersion (although not recommended for underwater operation). Mounting the sensor is best implemented by using the end clamps in conjunction with a standard 1" pipe welded into the process conveyer structure.

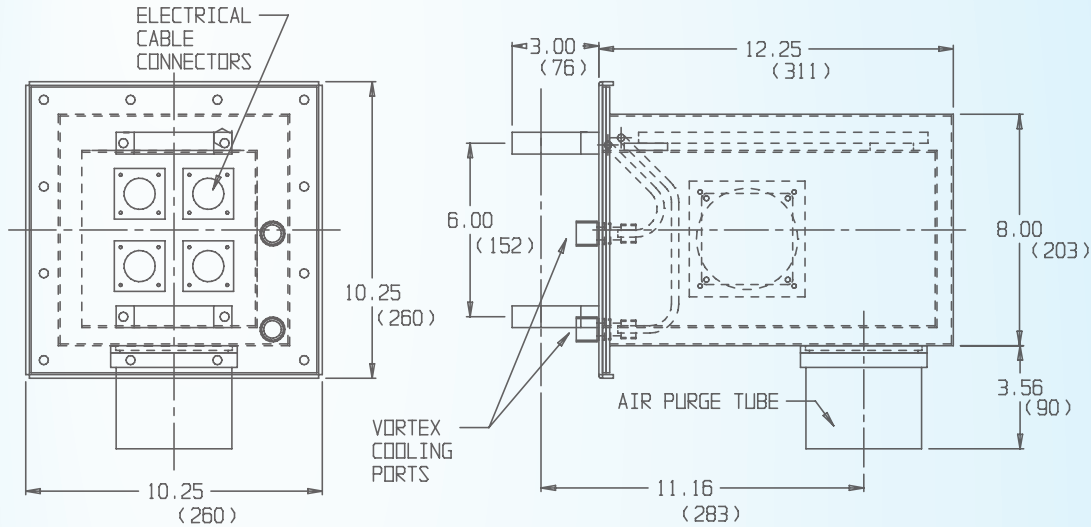

## SENSOR SPECIFICATIONS

Measured NIR Constituents:

Moisture Ranges:

Accuracy (subject to application):

Repeatability:

Optical Measurement Distance:

Sampling Size:

Calibration Codes:

Weight:

Enclosure:

Dimensions:

Power:

Operating Temperature:

Calibration:

Ambient Light Sensitivity:

Sensor Input/Outputs:

Optional interfaces:

1, 2 or 3 Moisture Ranges: Min 0.01%, Max 97%

0-0.1%, 0-100% PPM Ranges Subject to Application

±0.01%

±0.01%

4-16 in (10-40 cm)

Approximately 1.5-in (3.7 cm) diameter on sample

50 Standard

26 lbs.

IP-67 Stainless Sheet Metal

12.25 in x 10.25 in x 10.25 in.

80-260 VAC (50/60 HZ), Optional 24VDC

0-200F (93C)

Vortex Cooling (High Temp): Max 170°F (85°C)

Stainless Steel IP67: Max 200F (93C)

Factory Pre-Calibrated, PC Calibration software

included, Routine re-calibration is not required

None

Three self-powered isolated 4-20mA outputs,

RS-232/485, Ethernet TCP/IP

Profibus, Profinet, DeviceNet, Ethernet IP

*\*Above specifications are subject to application*

## OPTIONS & ACCESSORIES

In addition to the Display Options listed, MoistTech offers many installation options & accessories:

- Flange window with mounting (measure looking into a window)
- Bulk & Powder Sampler Cup (measure of falling material)
- Snorkel Sampler (measure into the conveyor wall)
- Air or Water Cooling for high temperature with optional auto on/off solenoid
- Product Loss Sample Hold Sensor
- Product Temperature Pyrometer

